

TANK MANUFACTURING & DIMENSION DETAIL

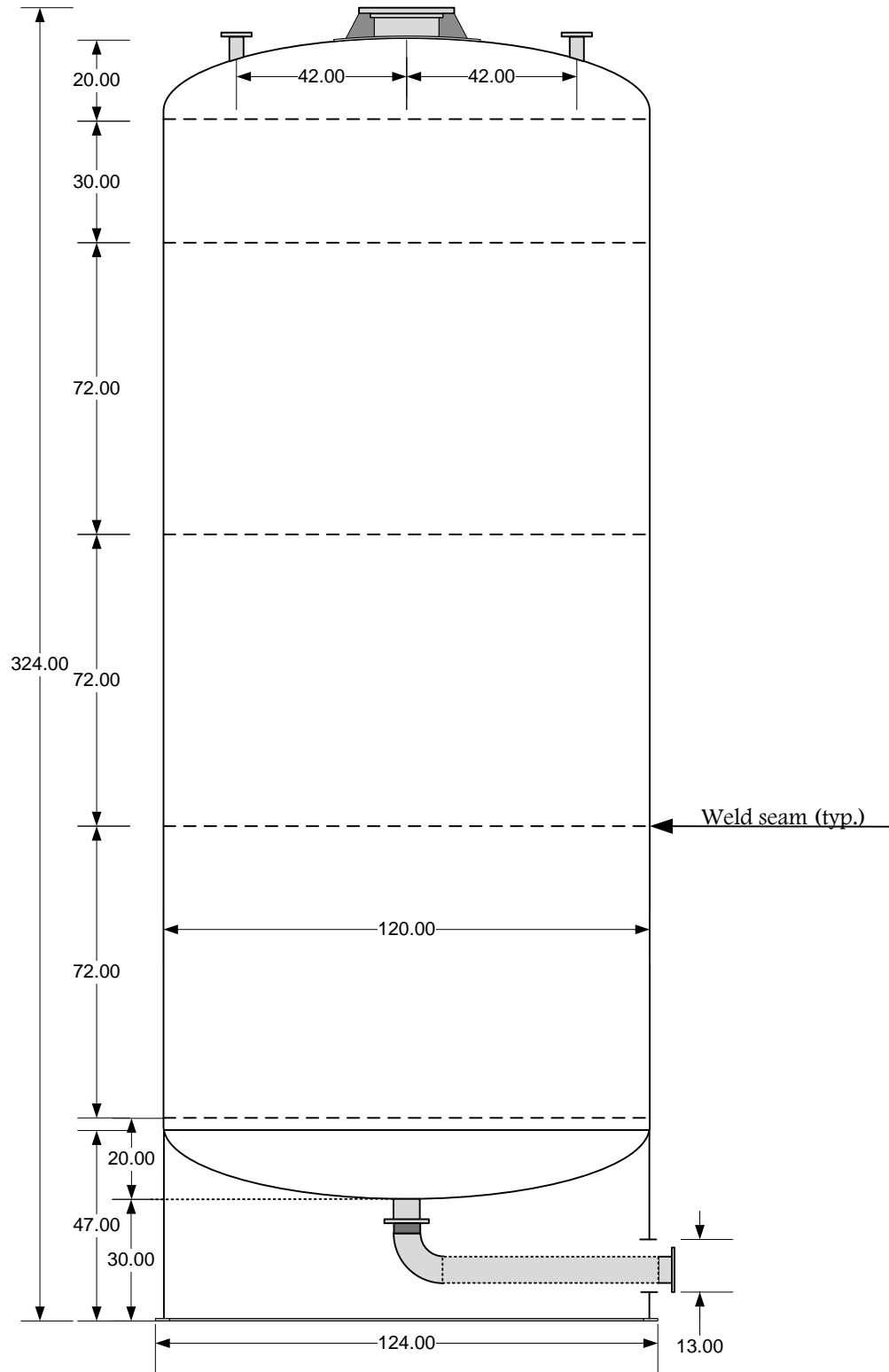

TANK MANUFACTURE: Modern Welding Co. Burlington, Iowa
 MAX WP: 15 PSI @ 150° F. VACUUM: 14.7 PSI @ 150° F. MFG'S SERIAL NO: S-4468
 DATE OF MFG: 1986 WEIGHT: 13,000 LBS CAPACITY: 13,000 GALLONS
 SHELL THK: .3125" HEAD THK: .387" SKIRT THK: .250" BASE PLATE: .625" x 3.5"

TANK INTERIOR SUPPORT DETAIL

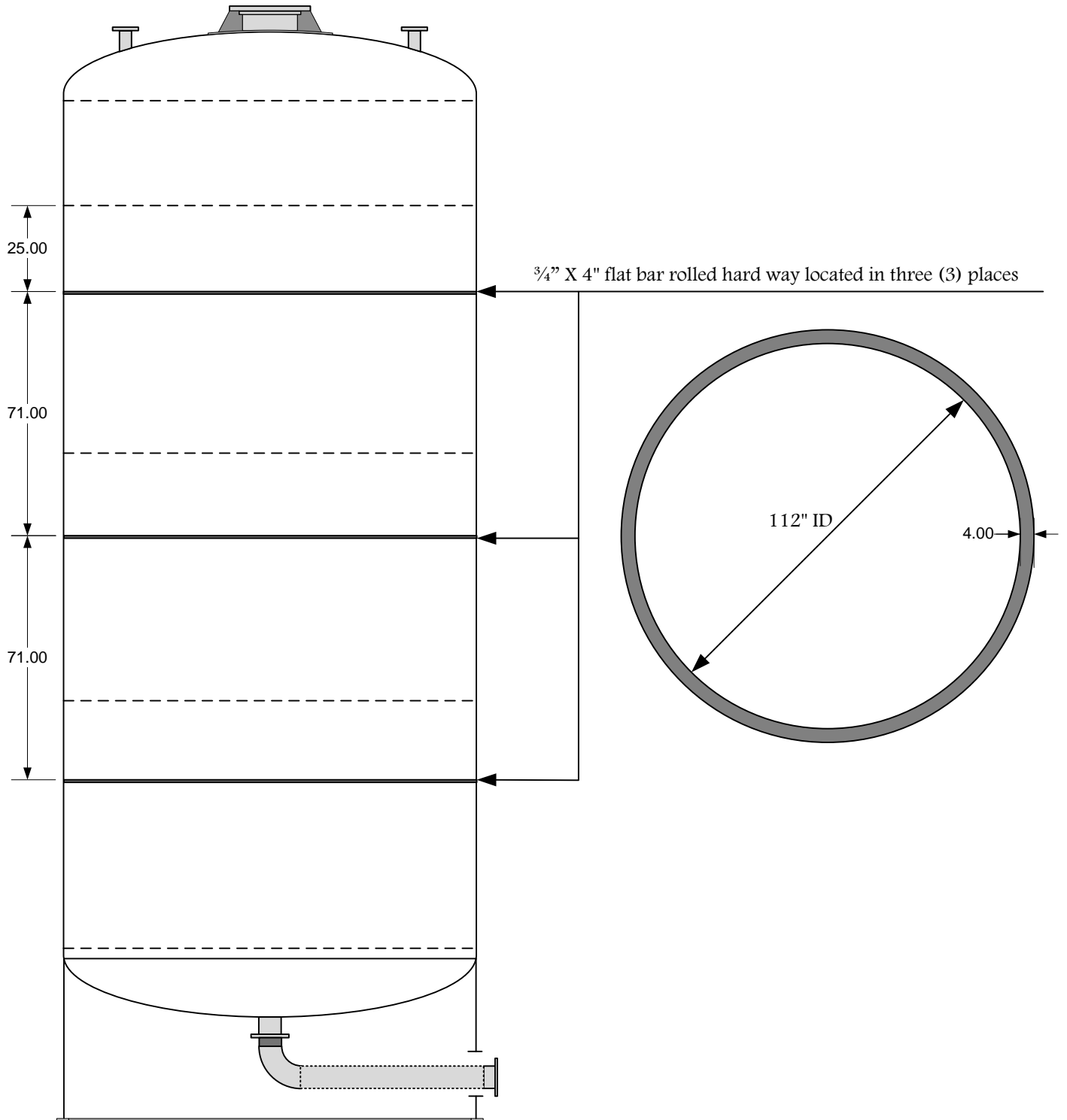

TANK TOP/HEAD DETAIL

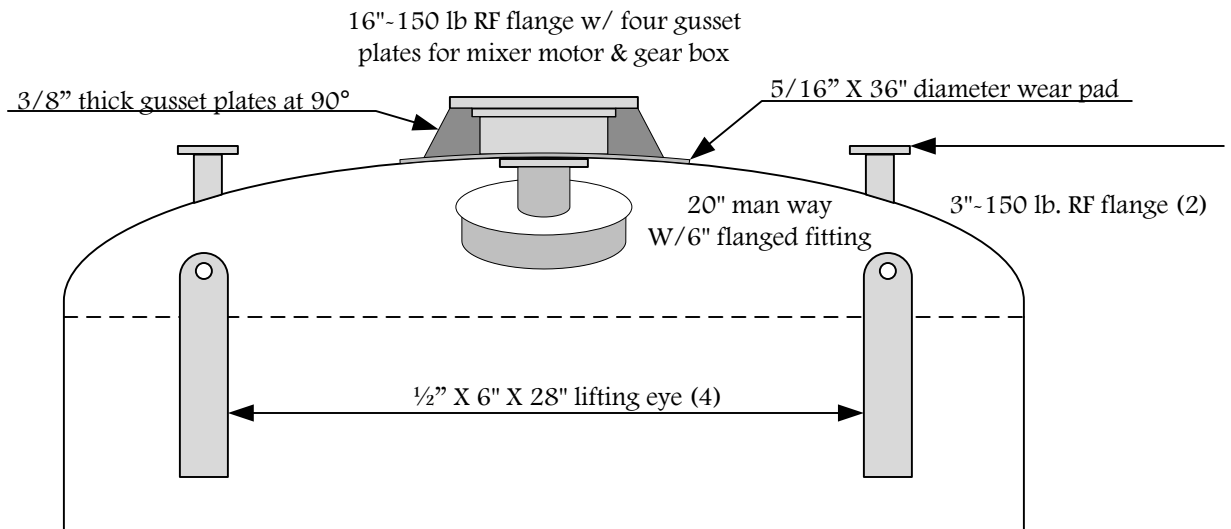
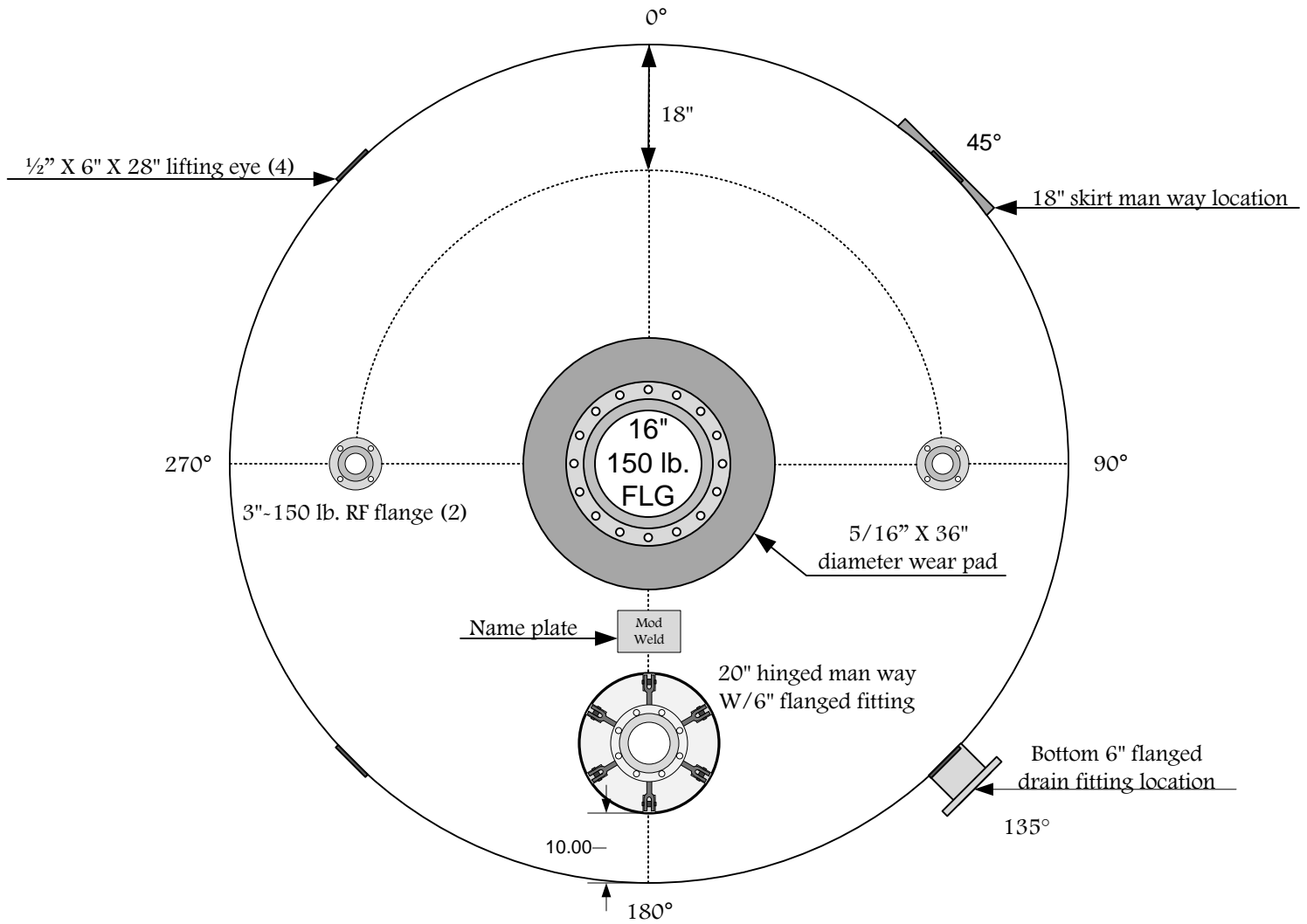

TANK BOTTOM/HEAD, SKIRT & BASE PLATE DETAIL

